

NOTES:

1. TO INSPECT ASSEMBLY, FOLLOW FIRST ARTICLE AND IN PROCESS INSPECTION SHEET.
2. APPLY LOCTITE 680.
3. SLIT O-RING, ITEM 8, BEFORE INSTALLING.
4. INSTALLATION TORQUE: 8-14 LB-FT.
5. ASSEMBLY SHALL BE WATER TESTED.
6. BAG 5-007 IN A SEPARATE BAG.
7. CUT O-RING, ITEM 9, TO .20" (SHORTEN BY .13") BEFORE INSTALLING.
8. APPLY LOCTITE 242.
9. APPLY THIN FILM OF DOW CORNING III
10. INSTALLATION TORQUE: 10-14 LB-IN.

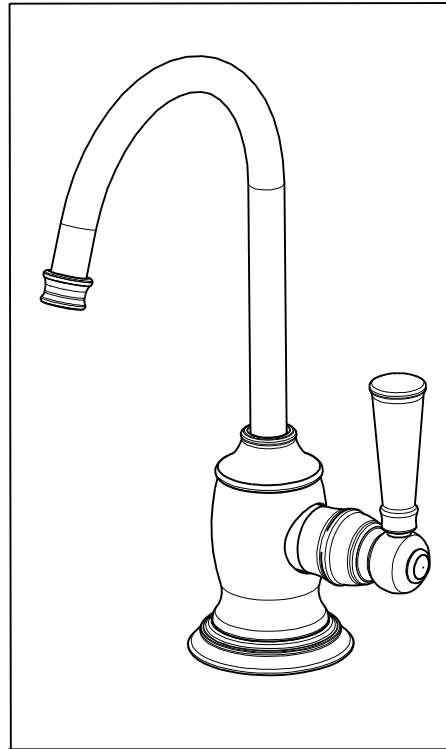

BILL OF MATERIAL (CURRENT LEVEL)

ITEM	PT/ASSY	DESCRIPTION	TYPE	QTY.
1	11731	ESCUTCHEON	PART	1
2	50703	WATER DISP. BODY (TRAD.)	PART	1
3	11732	CAP, BODY, WATER DISP	PART	1
4	11836	RETAINING RING	PART	1
5	91023	O-RING, #2- 019, EPDM, 65-75 DURO, NSF 61	PART	1
6	50713	SPOUT, WATER DISP. (TRAD.)	PART	1
7	11733	SHELL, SPOUT, WATER DISP	PART	1
8	91382	O-RING, #2- 012, TEFLON,	PART	1
9	91383	O-RING, #2- 014, TEFLON, NSF 61	PART	1
10	50714	WATER DISP. CAR.T HOLDER	PART	1
11	11734	BONNET	PART	1
12	1-134	CARTR 3/8 HOT 1/4 TR	PART	1
13	91017	O-RING, #2- 012, EPDM, 65-75 DURO, NSF 61	PART	2
14	91762	O-RING, #2-132, EP, 50 DURO - GREY	PART	1
15	50760	NIPPLE WATER DISP	PART	1
16	10661	MOUNTING STUD	PART	1
17	10514	MOUNTING CRESCENT	PART	1
18	91063	MOUNTING CRESCENT GASKET	PART	1
19	10516	MOUNTING NUT	PART	1
20	5-007	1/4 COMP KIT	ASSEMBLY	1
21	11834	ADAPTER	PART	1
22	92477	SCRW, M4 X 16 SKT FLT HD SS	PART	1
23	12747	BODY HANDLE	PART	1
24	11728	LEVER, HANDLE	PART	1
25	92192	SCRW, 10-32 X 5/8 SKT HD CUP PT SS	PART	1

-	J	EN-4300jj	04/12/21	R.S.
-	H	EN-3722	02/08/19	C.G.
-	G	EN-3976	10/01/19	J.M.
-	F	EN-3272	02/28/17	N.S
-	E	EN-2601	09/16/13	-
-	D	EN-2528	05/08/13	-
-	C	EN-2300	10/04/12	-
-	B	EN-2204	06/15/12	-
-	A	EN-2085	03/05/12	-
-	-	EN-1552-3	02/01/11	-
ZONE	REV	DESCRIPTION	DATE	APPROVED

COPYRIGHT 2005 BRASSTECH, INC. THESE DRAWINGS AND THE DESIGNS DEPICTED HEREIN ARE THE PROPRIETARY PROPERTY OF BRASSTECH. ANY USE OR REPRODUCTION IS SUBJECT TO THE EXPRESS APPROVAL OF BRASSTECH. UNAUTHORIZED USE IS STRICTLY PROHIBITED. ALL RIGHTS RESERVED.

TESTING	-	-	-
ASSEMBLY	-	-	-
PLATING	-	-	-
POLISHING	-	NEXT ASSY	USED ON
MACHINING	-	APPLICATION	
TOOLING FIXTURE #	REMOVE ALL BURRS AND SHARP EDGES		

UNITS ARE: INCHES [MM]
TOLERANCES ARE:

FRACTIONS DECIMALS ANGLES
±1/16" .X ±.1 [2.5] ±1°
.XX ±.06 [1.5]

(X.XXX) DENOTES CRITICAL DIMS.
ALL THREADS ARE CRITICAL

DRAWN	JINSON	04/12/21
CHECKED	R.S.	04/12/21
APPROVED	R.S.	04/12/21

BRASSTECH
INCORPORATED

2001 CARNEGIE AVE.
SANTA ANA, CA 92705
(949) 417-5207

COLD WATER DISPENSER

DWG NO.	2470-5623	REV	J
SCALE	.375	REF.	-
SHEET	1	OF	3

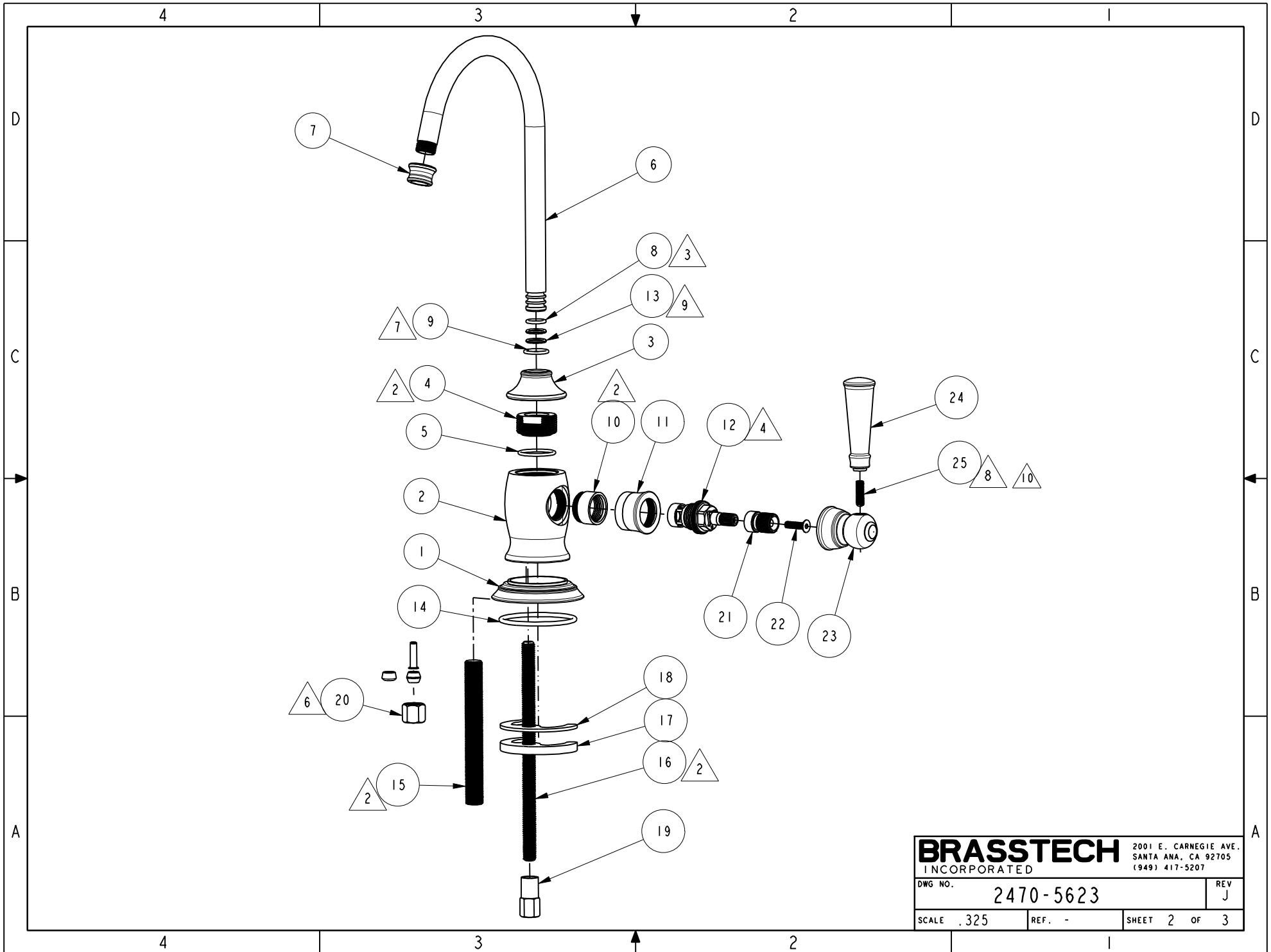

BRASSTECH		2001 E. CARNEGIE AVE. SANTA ANA, CA 92705 (949) 417-5207
DWG NO.	2470-5623	REV J
SCALE .325	REF. -	SHEET 2 OF 3

